

G1540 AquaGuard Gravity-Flow Portable Eye Wash, 16 Gallon



Application: Self-contained 16 gallon gravity flow eye wash unit uses gravity to deliver water through dual spray heads. Unit delivers over fourteen gallons (53 liters) of water for fifteen minutes, thus complying with the provisions of ANSI Z358.1-2004 for eye washes. Unit has a rugged plastic tank that can be installed in a wide variety of locations. Unit is ideal for use where a continuous supply of potable water is not available, especially in remote plant areas, low traffic and/or low hazard areas.

Tank: 16 gallon capacity safety green polyethylene tank. Tank has built-in carrying handle, heavy wall construction and reinforced ribs to support weight of unit.

Spray Head Assembly: Water flow is activated by pulling down on bright yellow eye wash tray. Integral full flow nozzles deliver soft spray of water. Swing tray up to storage position to stop flow.

Drain: Waste water is directed into drain opening in tank basin. 3 ft. long drain hose in basin directs discharge into floor drain, storage tank or other receptor.

Mounting: Furnished with epoxy coated steel bracket for mounting unit on wall. Unit can also be placed on countertop or other flat surface.

Preparation: Top operate unit, fill unit with clean potable water and add bacteriostatic additive (supplied with unit). Additive protects against growth of bacteria, fungus, algae and acanthamoeba. *Unit should be inspected regularly and water in unit should be changed at least once every six months.*

Discharge Time: Eye wash delivers .7 gallons per minute for 15 minutes.

Weight: 19 lbs. (8.6 kg.) empty, 145 lbs. (65.8 kg.) full.

Quality Assurance: Unit is completely assembled and water tested prior to shipment.

Available Options

- G1540BA**
8 oz. bottle of bacteriostatic additive to protect against growth of bacteria, fungus, algae, and acanthamoeba.



ETL Listed 101496.
Units have been tested
to and comply with
ANSI Z358.1 - 2004

GUARDIAN EQUIPMENT

660 North Union Street
Chicago, IL 60610
info@gesafety.com

Phone 312 733 2626
Fax 312 733 4684
gesafety.com

G1540

Portable Units

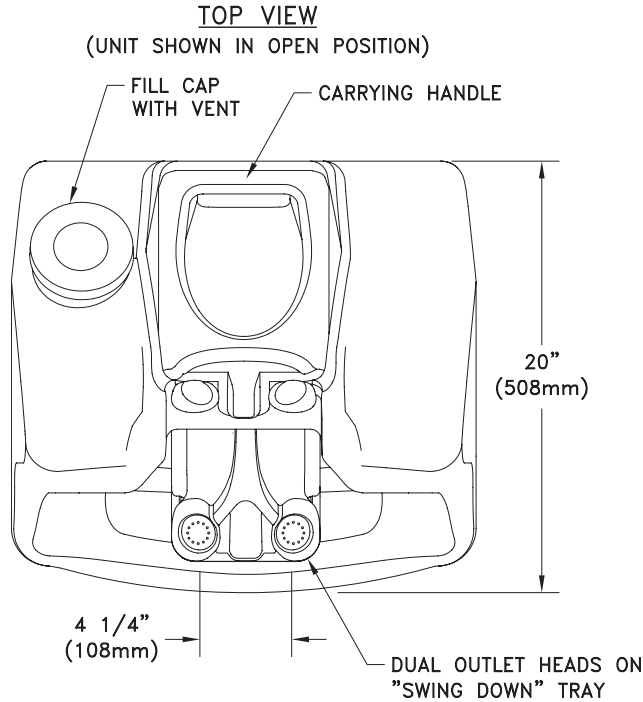

NOTES:

1. UNIT IS FURNISHED WITH WALL MOUNTING BRACKET AND 6 OZ BOTTLE OF BACTERIOSTATIC ADDITIVE TO PRESERVE WATER.
2. UNIT WEIGHS 15 LBS EMPTY, 156 LBS FULL.

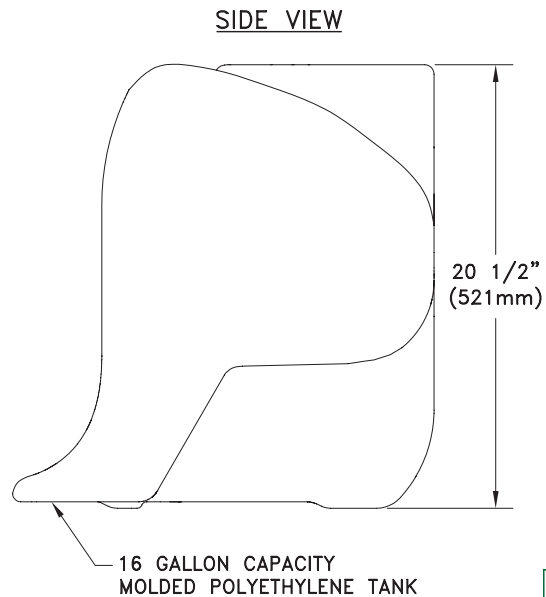
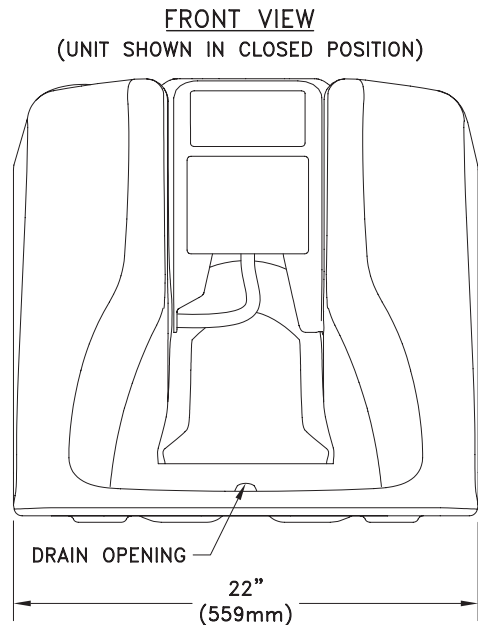

ETL Listed 101496.
Units have been tested
to and comply with
ANSI Z358.1 - 2004



Sign Included

This space for Architect/Engineer approval

GUARDIAN EQUIPMENT

660 North Union Street
Chicago, IL 60610
info@gesafety.com

Phone 312 733 2626
Fax 312 733 4684
gesafety.com